

# RIDEL G-CM

This range of **enameled** DHW heater Ridel/G-cm provides efficiency up to 90 % for powers going from 22 to 100 kW.

## Application field

- Residential field
- Hotels
- Industries

With its high efficiency and its compact design, the Ridel/G-cm allows you to heat your DHW at a low cost

## Specificities

- Enamelled steel tank compliant with DIN 4753-3 : The best alternative for a DHW storage with high sanitary requirements
- Energetics class : C
- Maximum working pressure of 7 bar
- Handhole (diam. 110 mm) for a regular maintenance
- Anti-rust protection with magnesium anodes or impressed current (in option)
- Adjustable power from 22 to 100 kW
- Extraction of burned gases by a vertical chimney
- Single-phase electric connection 230V



## Delivery kits

- Installation and maintenance manuals
- Equipment delivered on wooden pallet

## Accessories

- Insulating jacket in flexible PVC Euro Class B-M
- Thermostat control from +40 to +80°C
- Maximum safety storage temperature limited to 90°C

Photos non contractuelles

## Plan

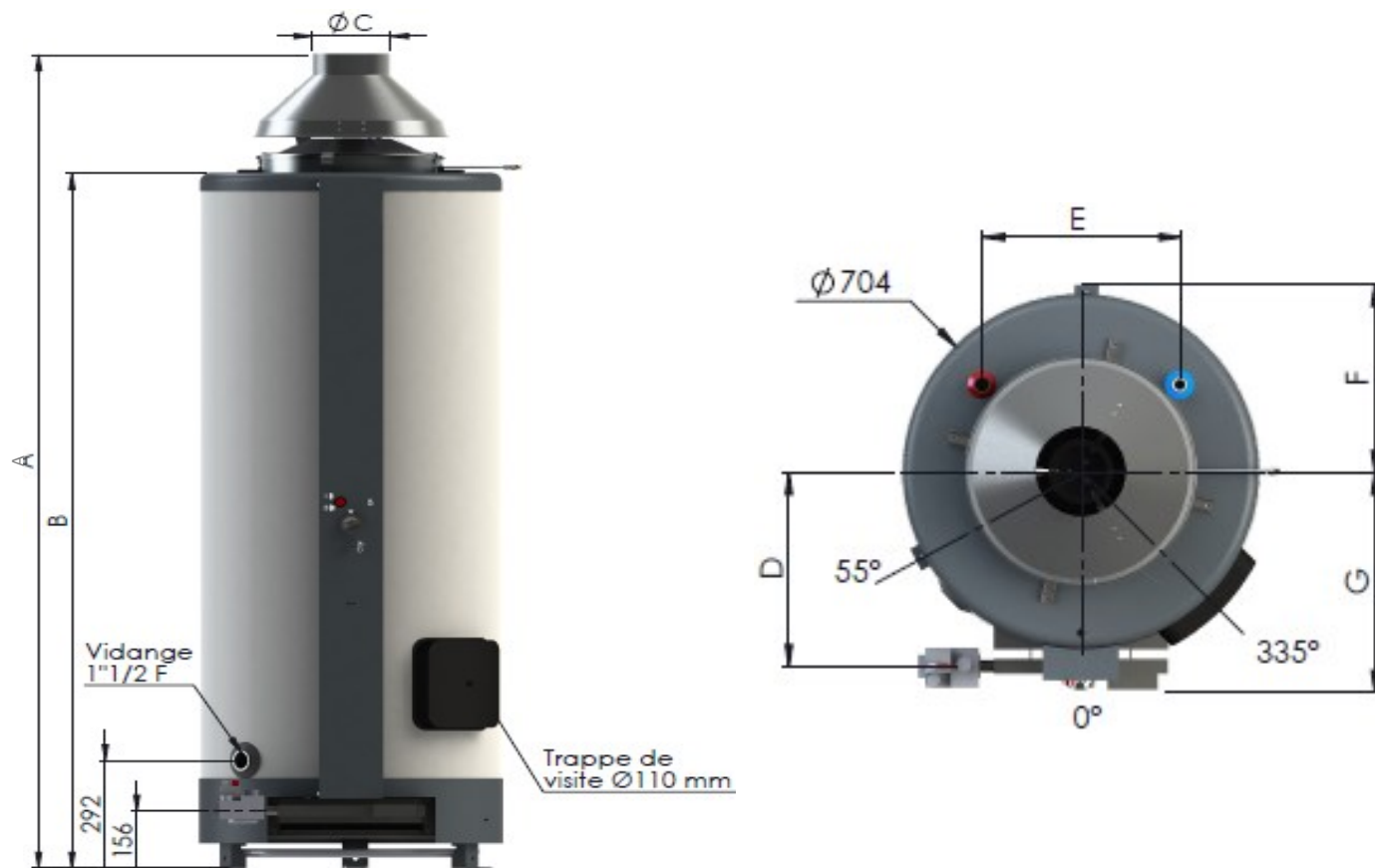

All dimensions are in millimeters

These dimensions are given for information purposes. A P&ID will be sent to you at the order.

## Technical data

Type	Capacity H.D.W	Heating capacity (thermal)	Usefull power	Heating time ( $\Delta T = 50^{\circ}C$ )	Continue production ( $\Delta T = 30^{\circ}C$ )		Maxi service temperature	Maxi service pressure	A	B	C	D	E	F	G	Tare weight
Unity	Liters	kW	kW	min	l/h	l/min	$^{\circ}C$	Bar	mm	mm	mm	mm	mm	mm	mm	Kg
G-CM 18	190	22	18,7	35	500	8,3	80	7	1468	1245	125	390	390	-	438	165
G-CM 26	275	34	28,9	32	800	13,3	80	7	1791	1560	139	385	390	-	432	196
G-CM 35	275	44	37,4	26	1045	17,4	80	7	1840	1560	167	385	390	-	432	196
G-CM 46	360	52	44,2	27	1220	20,3	80	7	2200	1920	167	385	390	-	432	245
G-CM 50	350	67	57	22	1600	26,7	80	7	2200	1920	181	385	390	-	432	245
G-CM 75	315	82	69,7	15	1950	32,5	80	7	2285	2025	230	385	-	402	432	298
G-CM 90	315	100	85	12	2350	39,2	80	7	2285	2025	230	385	-	402	432	298



Photos non contractuelles